

POCKET PLAN

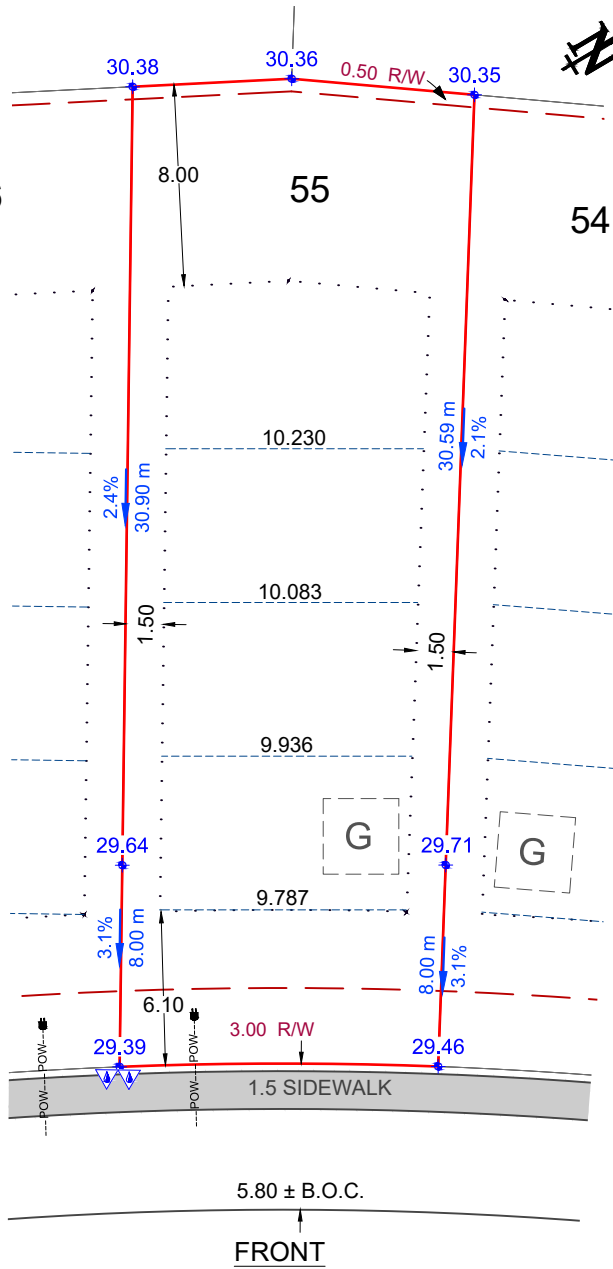
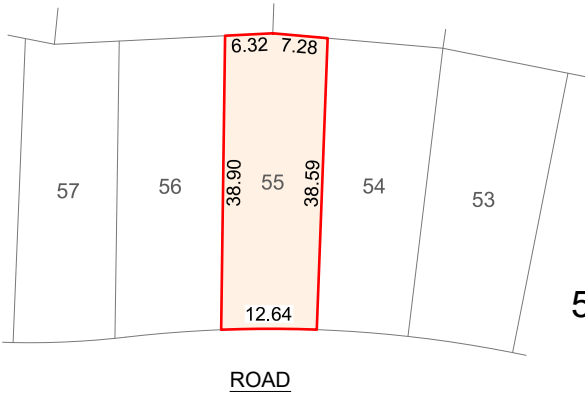

ELEVATION DETAILS	
HOUSE TYPE:	
FINISHED FLOOR:	
BOTTOM OF FOOTING:	
BASEMENT HEIGHT:	
FINISHED GRADE AT-FRONT STEP:	
FINISHED GRADE AT-BACK OF HOUSE:	
GRADE BELOW-BACK/SIDE DOOR SILL:	
GRADE BELOW-BASEMENT WINDOWS:	
TOP OF CONCRETE BASEMENT WALL:	
GARAGE FLOOR:	
SANITARY SEWER SERVICE INVERT:	26.64
FOOTING SIZE:	

NOTES

- BUILDER/OWNER RESPONSIBLE TO ENSURE BACK FILL LEVELS MEET ALL CODES.
- BUILDER / OWNER IS LIABLE FOR ANY COSTS INCURRED DUE TO AN ERROR IN THE ABOVE PLAN IF CONSTRUCTION STARTS PRIOR TO THIS PLAN BEING APPROVED BY THE LOCAL APPROVING AUTHORITY
- ALL DISTANCES SHOWN ARE IN METER AND DECIMALS THEREOF.
- INFORMATION TO BE USED AS A GUIDELINE ONLY, AND IS SUBJECT TO CHANGE.
- INFORMATION BASED ON UNREGISTERED PLAN, SUBJECT TO CHANGE.
- RAIN WATER LEADERS TO BE DETERMINED. (NO INFORMATION ON ENGINEERING, CONTACT ENGINEER PRIOR TO CONSTRUCTION)**
- STORM = 27.79

DETAILS	
- LOT AREA:	509.72 m ² (5486.6 ft ²)

LEGEND					
PROPOSED CLEAN OUT		PROPOSED HYDRANT		PROPOSED BACK OF CURB	B.O.C.
PROPOSED STREET LIGHT		PROPOSED SERVICE PEDESTAL		PROPOSED BACK OF WALK	B.O.W.
PROPOSED C.C. LOCATION		PROPOSED POWER SERVICE		PROPOSED LIP OF LANE	L.O.L.
PROPOSED TRANSFORMER		PROPOSED FENCE LINE		PROPOSED UTILITY VAULT	
					DESIGN GRADE ELEVATION 00.00
					AS-BUILT ELEVATION 00.00
					PROPOSED ELEVATION 00.00
					CENTERLINE ELEVATION CL 0.0

LEGAL INFORMATION		
LOT	BLOCK	PLAN NUM.:
55	7	192 1591
CIVIC ADDRESS:		
LOCATION	SUBDIVISION	
FT. SASKATCHEWAN	SOUTHFORT MEADOWS	

Pals Geomatics Corp.

EMAIL: POCKET@PALSGEOMATICS.COM
 PHONE: 780-455-3177
 FAX: 780-481-1301
 10704 - 176TH STREET NW
 EDMONTON, ALBERTA T5S 1G7

Canadian Home Builders Association Member

DWG DETAILS			
Rev. No.	Date:	Drafted By:	Description
PK 02	Mar. 18, 19 Jun. 25, 19	LMATYJANKA TBURVILL	REG. PLAN
BUILDER/OWNER:			
MODEL:			
JOB NUM.:			
LOT ZONING: R3		SCALE: 1:300	